

## **CEILINGS**

**KEY-LOCK® >**

**DUO® >**

**WALK-ABOUT™ >**

**STEEL STUD DRYWALL >**



# JUDAH KEY-LOCK® CONCEALED SUSPENDED CEILING SYSTEM

## SUMMARY

Whether you're looking to direct fix or fully suspend your plasterboard ceiling, the Judah KEY-LOCK Concealed Suspended Ceiling System is designed to produce high quality structure for flawless, flush or featured finish. The KEY-LOCK system can also be used as a framework to line virtually any existing wall or substrate

## SUITABLE FOR:

- Flush plasterboard ceilings
- Direct Fix or Fully Suspended applications
- Non-Fire Rated systems
- Fire Rated systems
- Acoustic Designs available
- Seismic Designs available\*

## SPECIAL FEATURES

- Able to be designed for external use, e.g. External Soffits
- Base Material Engineered from G2 BlueScope Steel for Strength and reliability
- Primary and secondary profiles available in custom lengths or radiuses

## IN PRACTICE

Since its initial introduction over 50 years ago, the design simplicity of the Judah KEY-LOCK® system has seen its use around the world in some remarkable projects from the *Setia City Mall in Malaysia*, to the *Crown Metropol in Melbourne*.

Some KEY-LOCK® components have also been manufactured with a specific radius to produce vaulted ceilings or curved walls, such as in the *Pod Pavilion in Malaysia*, and the *Aquatic Centre in Adelaide*, as well as the famous "sky ceilings" at the *Venetian Resort and Casino, Macau*.

\* Seismic activity varies significantly in the markets where the Judah KEY-LOCK® system may be installed and therefore Judah's Technical Services Department should be contacted for assistance.

## IMPORTANT NOTE:

Judah recommends its products and systems are installed by a qualified tradesperson and according to the relevant codes and standards outlined on page [256](#) of this manual.

## CONTENTS:

COMPONENTS [8](#)

### INSTALLATION DETAILS:

• SUSPENDED CEILINGS: NON-FIRE RATED [11](#)

• CONTROL JOINTS [14](#)

• EXTERNAL SUSPENDED CEILING SYSTEM [15](#)

• DIRECT FIXING OF FURRING CHANNEL BATTENS [16](#)

• BULKHEAD INSTALLATIONS [17](#)

### TYPICAL APPLICATION DETAILS:

• BULKHEADS [18](#)

• CURVED CEILINGS [19](#)

• RAKED & CANTILEVERED CEILINGS [20](#)

METAL CEILING BATTENS DOMESTIC [21](#)

119 U CLIP [24](#)

EXPRESS JOINT: CEILINGS [26](#)

PRODUCT DATA SPECIFICATIONS [29](#)

SPAN TABLES [31](#)

LOAD TABLES [36](#)

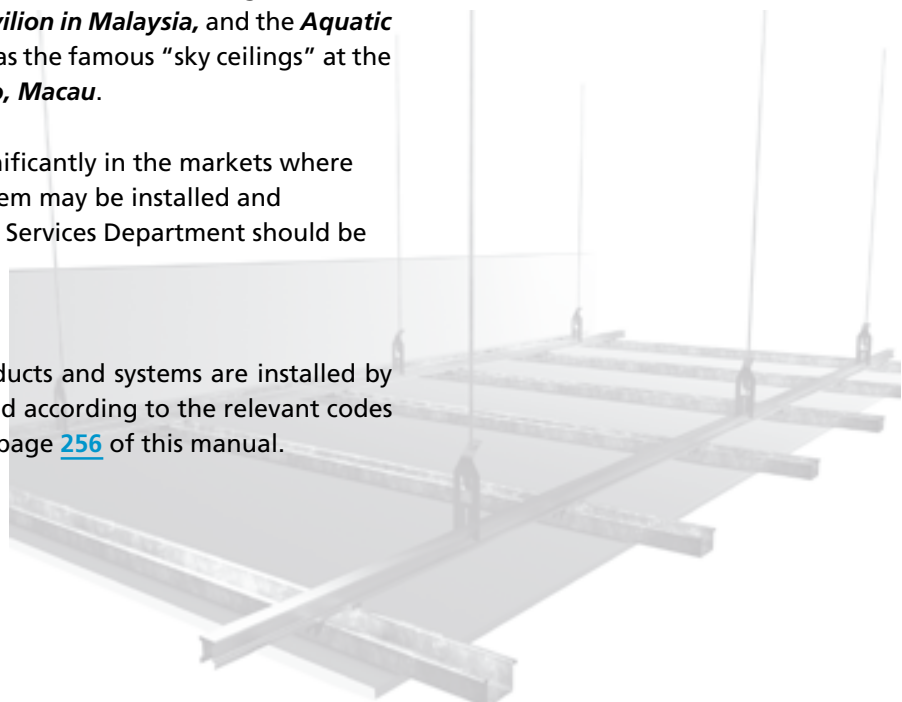

# JUDAH KEY-LOCK® COMPONENTS

## PRIMARY SECTIONS

125	1" Top Cross Rail 22 GA
127	1" Top Cross Rail 20 GA
128	2" Top Cross Rail 20 GA

## PRIMARY SECTIONS



## FURRING/BATTEN SECTIONS

129	1" Furring Channel
155	Wide Furring Channel with 3/8" Express Joint
308	5/8" Furring Channel
301	5/8" Ceiling Batten
303	1" Cyclonic Ceiling Batten
310	1 3/8" Ceiling Batten
333	1/2" Recessed Furring Channel
581	Resilient Channel
B005	Back Blocking Batten

## FURRING/BATTEN SECTIONS



## SECTION JOINERS

138	Furring Channel 129-308
272	Top Cross Rail 125-127-128
312	Joiner 310
315	Nail-up Batten 301

## SECTION JOINERS

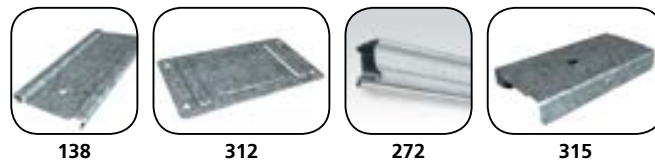

## PRIMARY TO SECONDARY JOINERS

119	Judah U Clip
139	129-308 to 127-128
159	155 to 127-128

## PRIMARY TO SECONDARY JOINERS



## BULKHEAD TRIM

321	Aluminium Direct Fix-TW - 1/2" PB
-----	-----------------------------------

## BULKHEAD TRIM



## WALL TRIMS

140	Furring Channel Wall Track to suit 129
142	Wall Track to suit 308
340	Wall Track to suit 310
DUO5	Wall Angle 1" x 3/4" Steel
DUO6	Wall Angle 3/4" x 1/3" x 1/3" x 5/8" Aluminium Shadowline
P51	Shadowline Combination Set Bead for 10mm Board
P52	Shadowline Combination Set Bead for 1/2" Board
P53	Shadowline Combination Set Bead for 5/8" Board

## WALL TRIMS



**DIRECT FIXING CLIPS**

156	Direct Fix Clip Timber/Steel for 155
157	Direct Fix Clip Masonry for 155
166	125-127-128 to Timber/Steel
226	129-308 to Timber/Steel
237	129-308 to Concrete
239	129-308 to Concrete-Screw Fix
282	Direct Fix FC Clip for Membrane Insulation
305	301 to Timber/Steel 150mm long
307	301 to Timber 90° DFC
311D	Direct fixing clip 310
313	Extended direct fixing clip for 310
314	DFC with positioning tab for 301 Batten to Timber/Steel 92mm
390	301 Batten Swivel Clip
394	129-308 to Timber/Steel
A124	TCR Assembly Clip with adj. through bolt
A239	FC Assembly Clip with adj. through bolt
BG01	BETAGRIP1 Standard Clip
BG02	BETAGRIP2 Long Clip
BG05	BETAFIL Double Membrane Insulation Clip
FC-INFIN0030	Sliding Adjustable Furring Channel Clip
FC-INFIN0080	Long Sliding Adjustable Furring Channel Clip
TCR-INFIN090	Sliding Adjustable Top Cross Rail Clip

**DIRECT FIXING CLIPS**



**SUSPENSION BRACKETS FOR RODS**

247	121 to Concrete
274	121 to Timber/Steel Joist
534	Adjustable Suspension Hanger (Purlins)
547	Adjustable Suspension Hanger (Concrete)

**SUSPENSION BRACKETS FOR RODS**

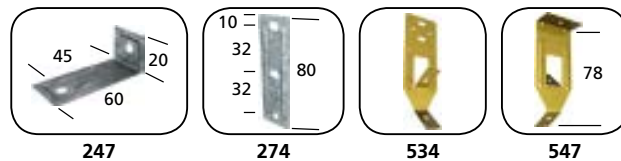

**SUSPENSION CLIPS**

124	125-127-128 Thread Adj.
124N	124 with threaded nut 127-128
167	Side mounted TCR Suspension Clip
2534	TCR Suspension Clip
254	121/121 or 121/122 Joiner Spring Adj.

**SUSPENSION CLIPS**

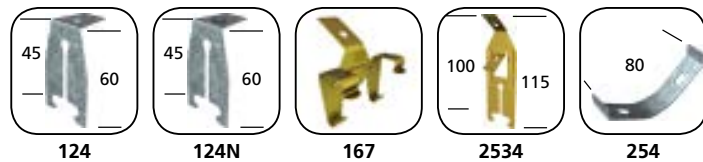

# JUDAH KEY-LOCK® COMPONENTS (continued)

## SUSPENSION RODS & NUTS

121	5mm soft galv. rod: plain
122	5.3mm soft galv. rod: M6 threaded one end
826	M6 nut to suit threaded rod

## SUSPENSION RODS & NUTS

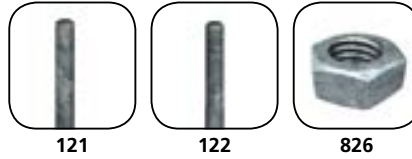

## ACCESSORIES

130	Rod Bender
545	L Bracket 75 x 75 x 1.50bmt
709	Joiner – DUO5
717	Bulkhead clip – screw fix

## ACCESSORIES



## RADIUSSED WALL TRIMS

242D	Shadowline Aluminium Column Trim
242R	Shadowline Aluminium Wall Angle
243D	'L' Column Trim
243R	'L' Wall Angle

# INSTALLATION DETAILS

## Suspended Ceilings for Internal Applications

**Note:**

The work shall comply with the requirements of the Standards listed in this manual on page 256, and undertaken by qualified trades persons.

**STEP ONE**

Fix Furring Channel Track along both walls and at 90° to the direction of the Furring Channel.

**STEP TWO**

Cut Suspension Rod to length. Attach Direct Fixing Clip (534 or 547) to one end and TCR clip 2534 to the other. Fix assembly to one side of the truss, purlin or concrete slab with appropriate fixings (as in Figures 1 & 2) and at required centres (see span tables, page 31). Refer to Figures 3 & 7 for information on positioning of Hangers, Top Cross Rail and Wall Track.

**STEP THREE**

Adjust all Hangers to correct drop using string line or laser.

**STEP FOUR**

Attach Top Cross Rails to suspension clips. Join primary rails end to end using Joiner 272. Also using Joiner 272 on each end of the Top Cross Rail run, tap joiner up against the walls to stabilise the system (refer Figures 3 & 4.)

**NOTE:**

For fire rated systems, leave a 20mm gap at the end of each Top Cross Rail.

1



Suspension rod bracket Part No 534

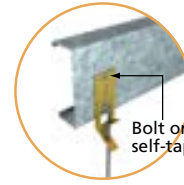

Bolt or self-tapping screw



Suspension rod bracket Part No 547

■ SUSPENSION BRACKETS FOR RODS

2

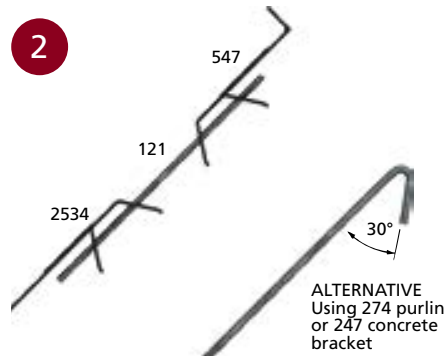

■ SUSPENSION ROD ASSEMBLY

4

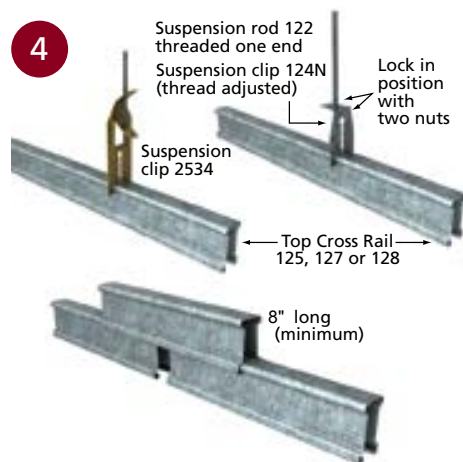

■ TOP CROSS RAIL ATTACHMENT

3

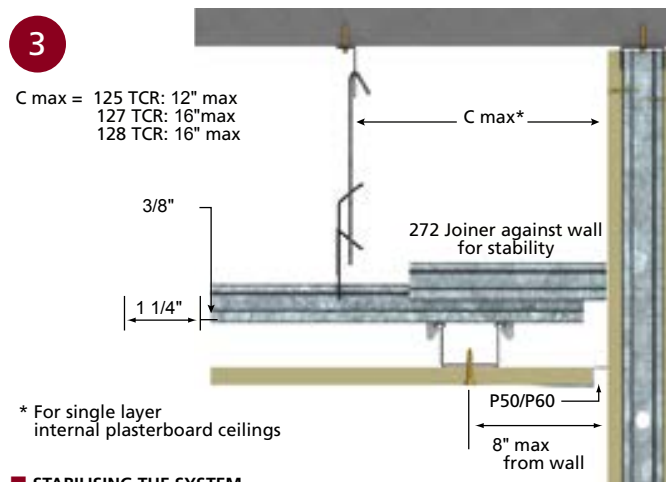

■ STABILISING THE SYSTEM

\* For single layer internal plasterboard ceilings

# INSTALLATION DETAILS (continued)

## Suspended Ceilings (continued)

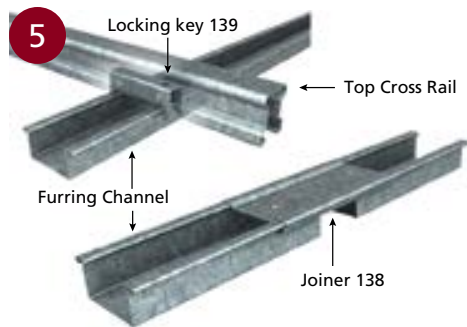

### CONNECTING TO FURRING CHANNEL

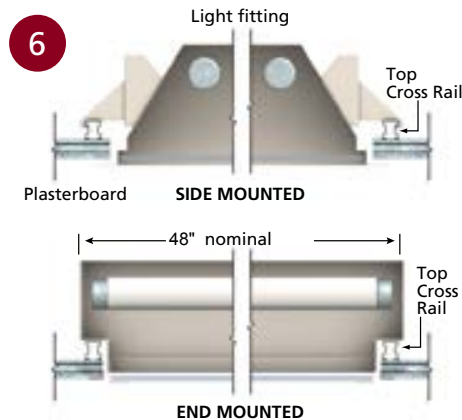

### LIGHT FITTINGS (nominal 1200x600mm)

Note: Additional suspension is required to carry light fittings or other ceiling attachments.

### STEP FIVE

Use the 139 Locking Key to connect both the Top Cross Rail and Furring Channel together. Space the Furring Channel at the building board manufacturers specifications and our tables on pages 36-38.

Join the Furring Channels end to end using 138 Joiners (see Figure 5). Ensure that the ends of the Furring Channel are connected into the Furring Channel Track.

#### NOTE:

For fire rated systems, leave a 20mm gap at the end of each Furring Channel and TCR.

Joints in the Furring Channels and Top Cross Rails should be staggered throughout the ceiling grid (refer to building board manufacturer for recommended spacing).

### STEP SIX

Install lining sheet as per the building board manufacturer's recommendations. Light fittings and air conditioning grills can also be installed (refer Figure 6).

#### NOTE:

As referenced in AS2785/2000, the ceiling grid is only designed to accept a distributed service load of 3 kg/m<sup>2</sup>. For additional loads, consult the maximum load tables on pages 36-38.

### STEP SEVEN

For examples of typical perimeter finishing methods, refer Figures 3 & 8.

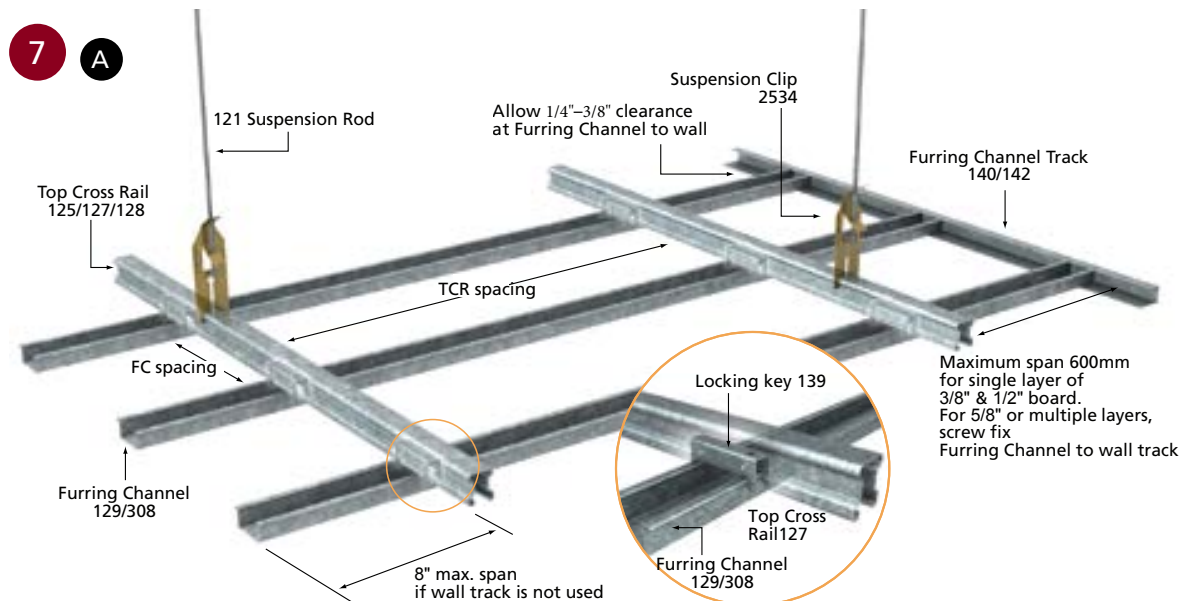

### KEY-LOCK® SUSPENDED CEILING

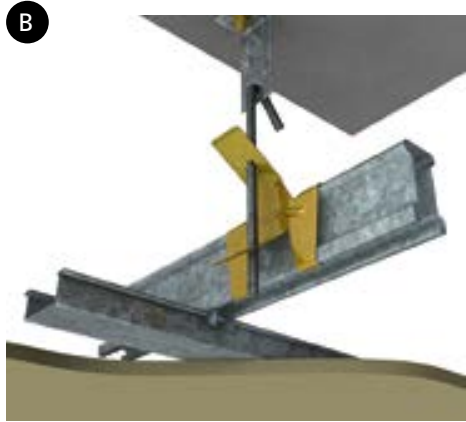

■ TCR SIDE MOUNT CLIP 167

NOTE:  
167 Top Cross Rail Side Mount Clip is only suitable for a single layer of board.



■ INFINITI SLIDING ADJUSTABLE CLIP TO TCR

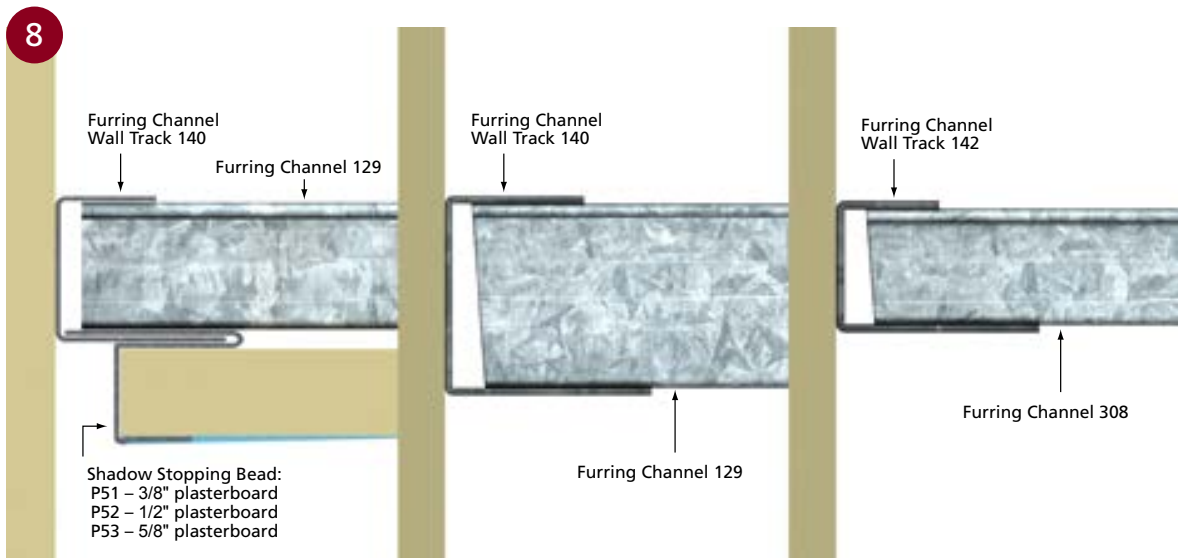

■ FURRING CHANNEL WALL TRACKS

Note: Leave a minimum gap of 5-10mm between Furring Channel and wall track



# INSTALLATION DETAILS (continued)

## Control Joints for Internal Applications

Control joints allow for expansion and contraction movements in buildings.

Judah P35 Control Joint section should also be used when a building board surface abuts a dissimilar wall assembly. It is also recommended by the building board manufacturers that Judah P35 Control Joints are installed when continuous ceiling lengths exceed 12m in any direction.

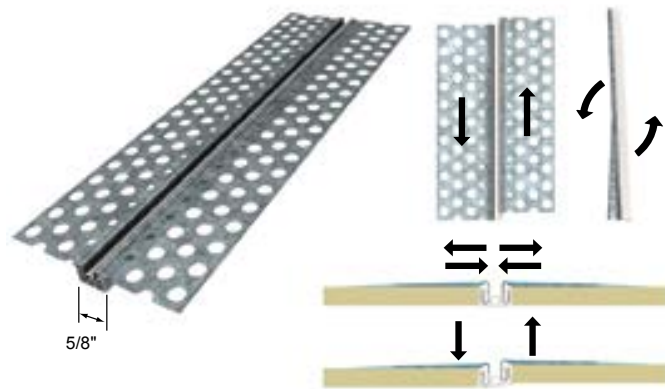

9

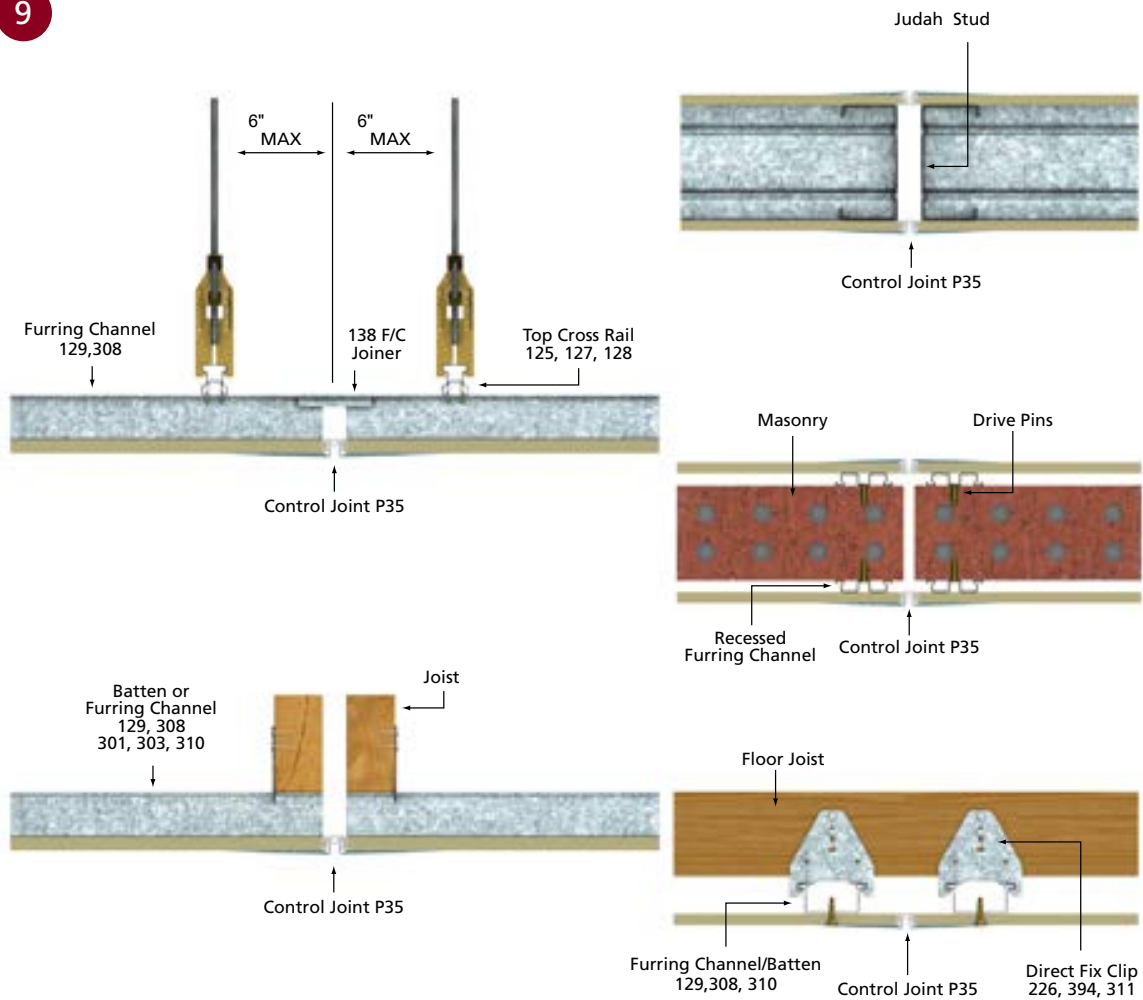

■ CONTROL JOINTS

## Suspended Ceiling System for External Applications

When installing the Judah KEY-LOCK® suspended ceiling system in external applications, consideration should be given to wind pressure which may occur. For Downstrut details, refer to Figure 10.

### WIND LOADING TABLE

The accompanying table shows the maximum spacing for part number 128 Top Cross Rail and maximum suspension point spacing along the Top Cross Rail for the wind pressures indicated. The limit state loading needs to be determined in accordance with AS/NZS1170.2 and the load combinations specified in AS/NZS 2785.

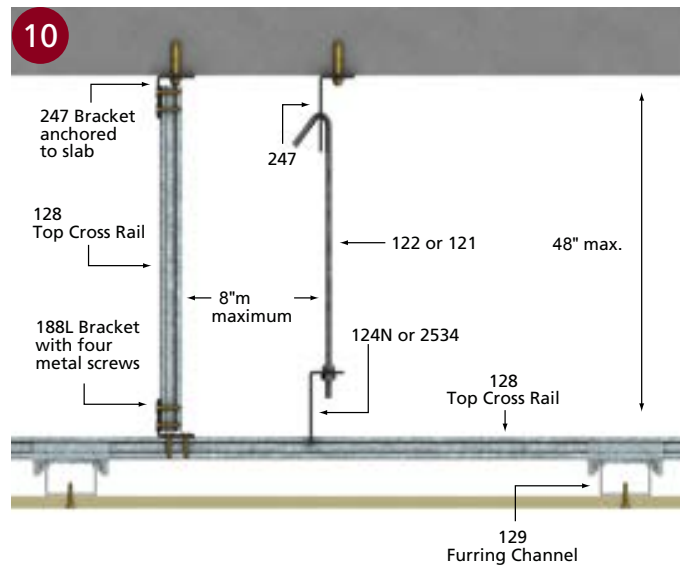

The downstrut acts in compression under an upward wind load and therefore nominal fixings are required at either end.

### NOTE:

Check with the building board manufacturer for correct spacing of Furring Channels (part number 129).

**TABLE 1: ULTIMATE LOAD CAPACITY FOR 128 TOP CROSS RAIL**

SUPPORT CONFIGURATION		LIMIT STATES	
TCR SPACING (Inch)	TCR SUPPORT CENTRES (Inch)	ULTIMATE LIMIT STATE (kPa)	SERVICABILITY LIMIT STATE (kPa)
24"	48"	0.24	0.24
36"	48"	0.32	0.32
36"	36"	0.79	0.79
36"	24"	1.19	1.19
24"	24"	2.60*	2.60*

- NOTES: 1. The above table gives the limit state load capacity for various ceiling configurations. The direction of loading may be upward or downward, provided the ceiling is installed with downstrutting as per Figure 10.  
 2. Slab connections to be independently checked.  
 3. Serviceability limit state deflection limited to L/250.  
 4. Lining contribution has been ignored in analysis.  
 5. Number 129 Furring Channels to be installed at 600 ctrs for TCR span=48" and 450 ctrs for TCR span=36" or less.  
 6. Limit state load combinations to be calculated in accordance with AS/NZS 1170.0 or AS/NZS 2785.  
 7. \* Capacity controlled by connections.

# INSTALLATION DETAILS (continued)

## Direct Fixing of Furring Channel Battens for Internal Applications

Direct fixing of Furring Channels and battens to either concrete, steel or timber wall or ceiling structures can be done using one of the many direct fixing clips as shown in Figure 11.

The maximum drop for direct fixing should be limited to 200mm. Any drop greater than 200mm requires a full Judah suspension system.

Direct fixing clips need to be fixed along the sections in accordance with the relevant maximum span tables.

Furring channels should be spaced in accordance with the building board manufacturers recommendations.

### IMPORTANT NOTES:

It is not recommended to screw or nail fix battens or Furring Channels directly to timber joist supporting a trafficable floor due to deflection of the joist occurring and possible subsequent interaction with the ceiling batten. Use only direct fixing clips as shown on page 9.

The BETAGRIP BG01/02 when used for Ceilings should only be secured with One Centre Fixing (i.e. Use Centre Hole Only).

11



**BETAGRIP BG01/02 to Furring Channel**  
NOTE: Centre fixing Only

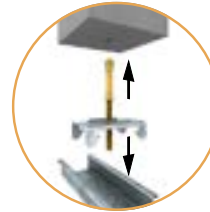

**A239 to Furring Channel**

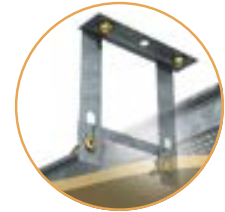

**Long INFINITI clip to Furring Channel**



**394 clip nailed to joist Furring Channel**



**226 clip nailed to joist Furring Channel**



**305 clip nailed to joist Ceiling Batten**



**314 clip nailed to joist Ceiling Batten**



**390 Swivel Clip nailed to joist Ceiling Batten**



**166 clip nailed to joist Top Cross Rail**



**A124 to Top Cross Rail**

■ DIRECT FIXING CLIPS

## Bulkhead Installation for Internal Applications

The Judah Square Line Bulkhead System allows easy, economical and true bulkhead corner finishes to be achieved by using concealed support clips and fixings.

### STEP ONE

Install the metal framework and fix the building board to the horizontal surface.

### STEP TWO

Attach Support Clip 717 to the framework, with the bottom leg hard up against the building board. A string line can be used to assist if required (refer Figure 12).

### STEP THREE

Introduce the Bulkhead Trim DUO 5 to the support clips (refer Figure 13).

### STEP FOUR

Join Bulkhead Trim end to end using Joiner 709 to give a flush finish (refer Figure 14).

### STEP FIVE

Introduce the vertical building board as shown below, and screw fix to the framework (refer Figure 15).

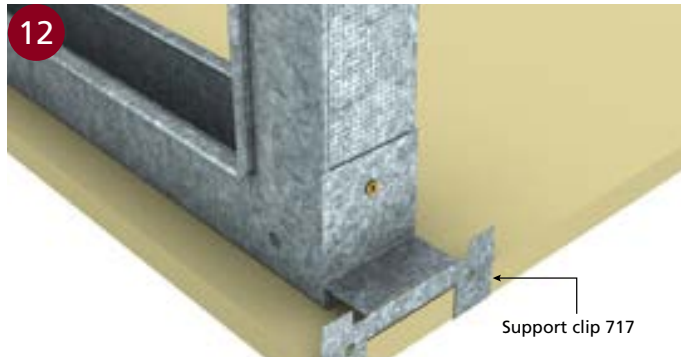

■ SUPPORT CLIPS

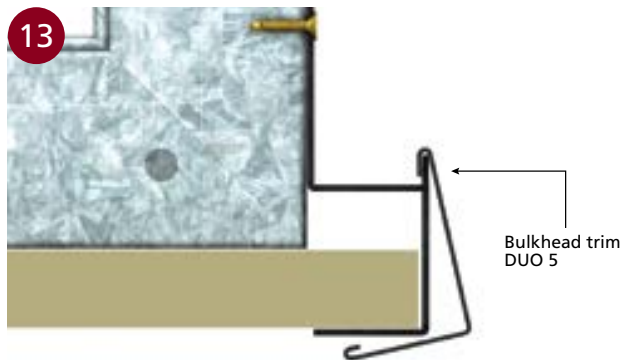

■ BULKHEAD TRIM

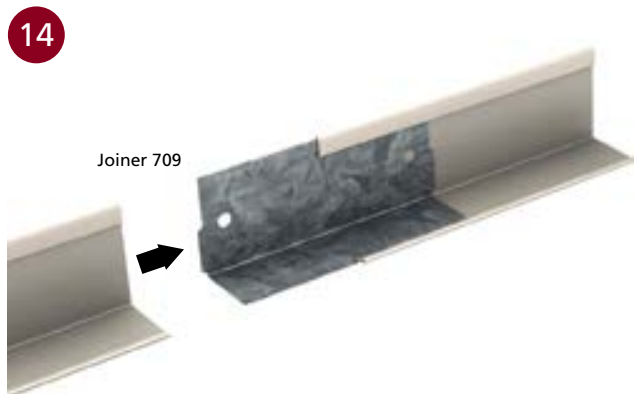

■ BULKHEAD DETAILS

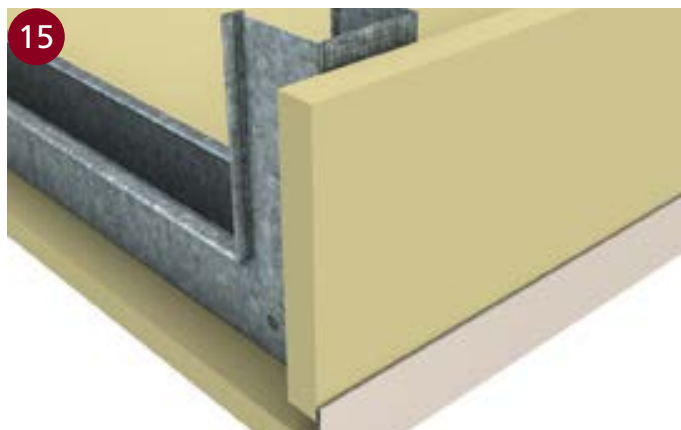

■ VERTICAL MEMBERS

# TYPICAL APPLICATION DETAILS

## Bulkheads for Internal Applications

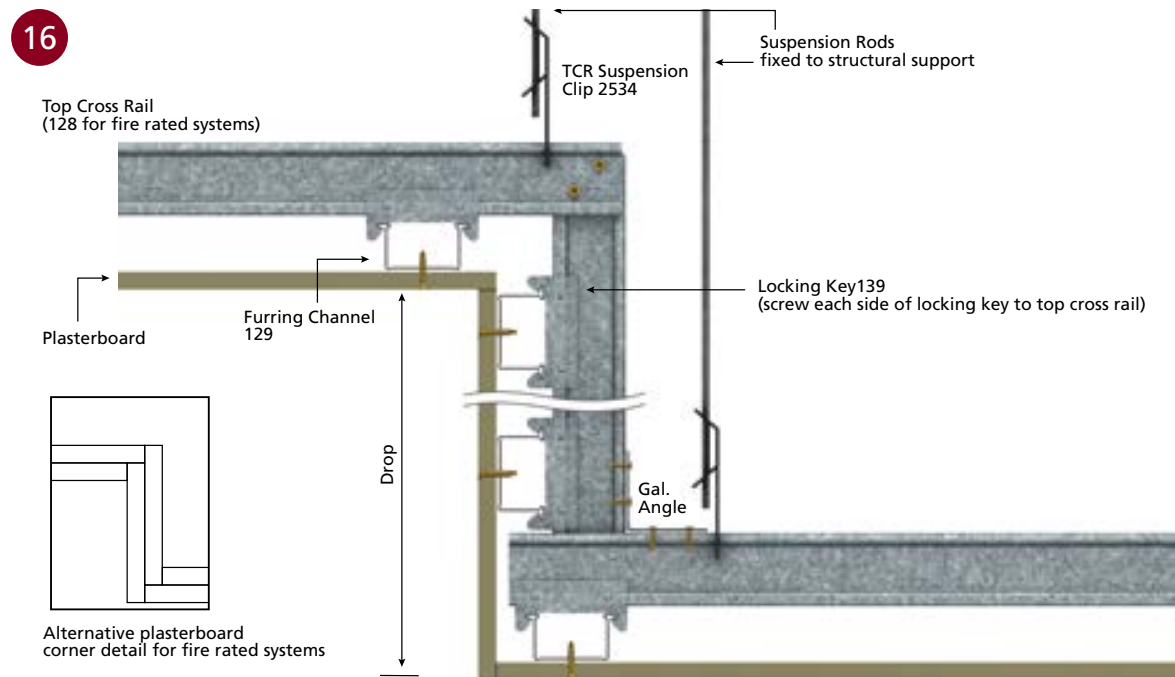

■ FRAMED BULKHEAD 'A'

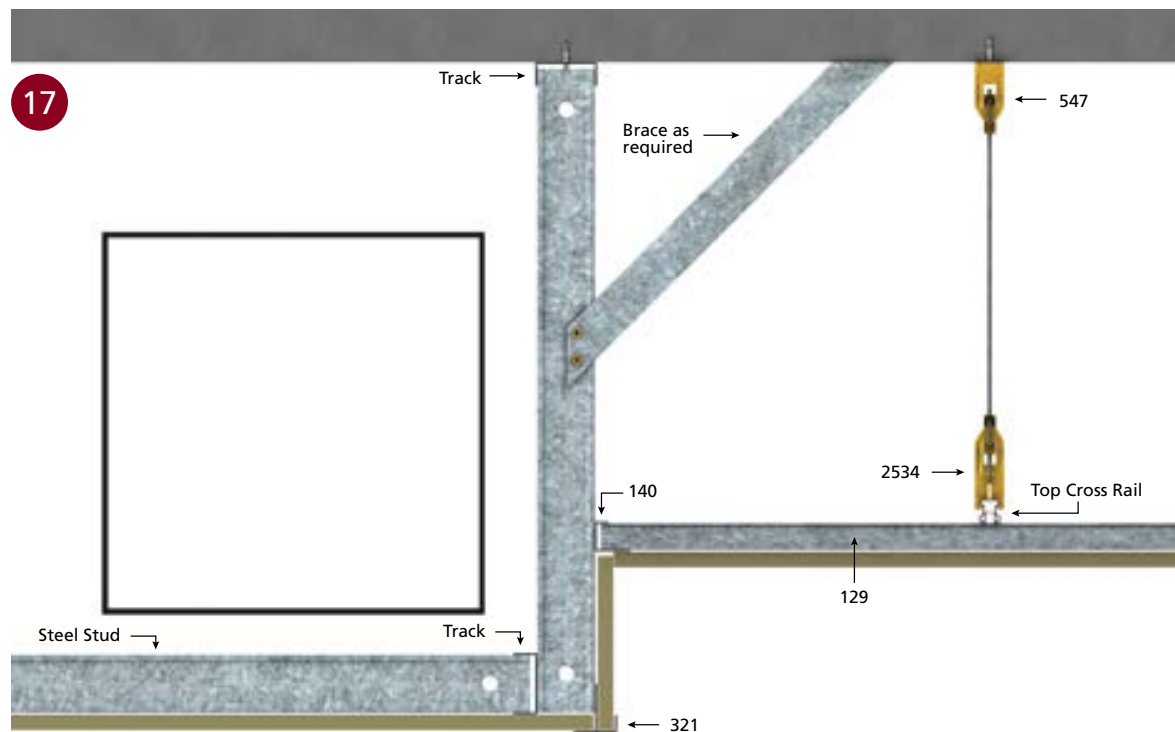

■ FRAMED BULKHEAD 'B'

**NOTE:**

The maximum drop of bulkheads is not to exceed 1200mm for suspended bulkheads.

## Curved Ceilings for Internal Applications

18

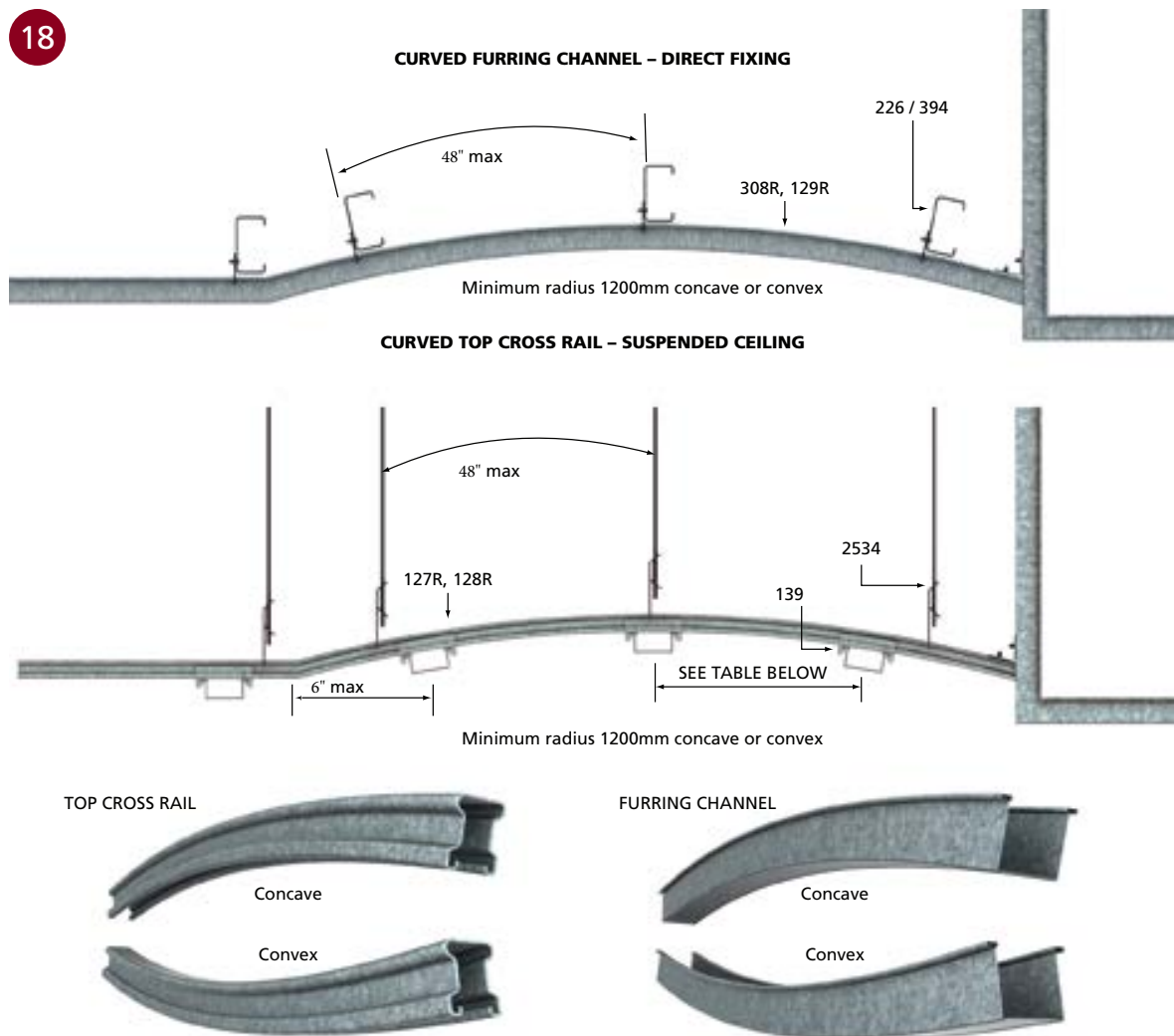

■ CURVED CEILING DETAILS

TABLE 2: MAXIMUM FURRING CHANNEL CENTRES FOR CURVED CEILINGS

PLASTERBOARD THICKNESS (Inch)	CEILING CURVE RADIUS (ft.)						
	3'-3.5'	3.5'-5'	5'-6.5'	6.5'-8'	8'-10'	10'-13'	13' +
	MAXIMUM FURRING CHANNEL CENTRES (Inch)						
1/4"	6"	8"	10"	12"	14"	18"	22"
3/8"	6"	8"	10"	12"	14"	16"	22"
1/2"	-	6"	10"	10"	14"	16"	20"
5/8"	-	-	-	-	-	10"	14"

# TYPICAL APPLICATION DETAILS (continued)

## Raked & Cantilevered Ceilings for Internal Applications

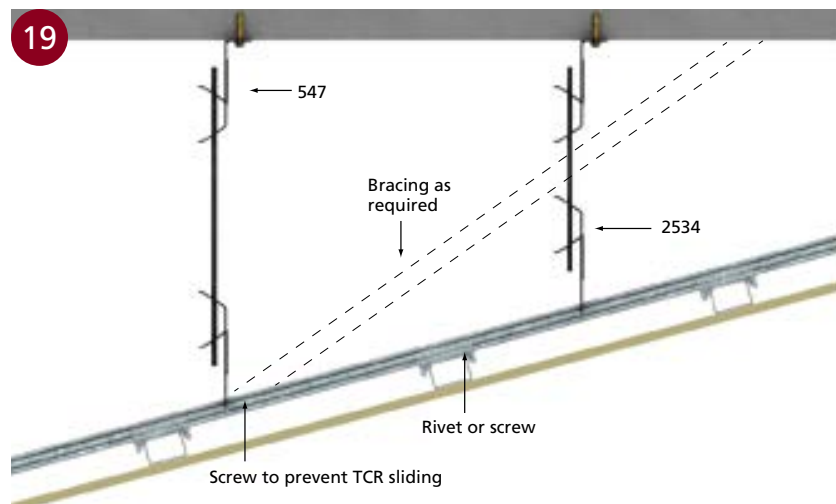

■ FOR RAKING AND CURVED CEILINGS

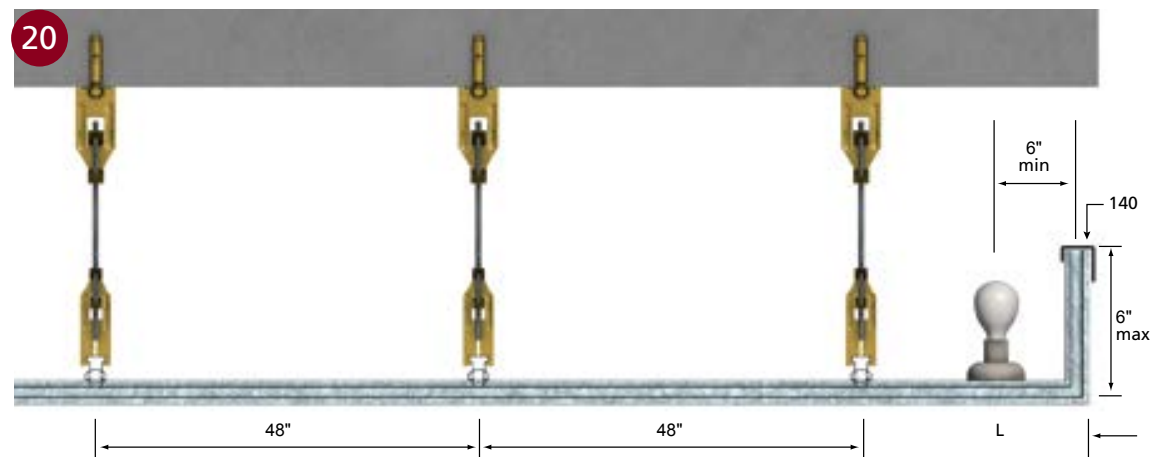

■ FURRING CHANNEL-TOP CROSS RAIL: CANTILEVER DETAILS

TABLE 3: MAXIMUM CANTILEVER (L) FOR ONE LAYER 3/8"/1/2"/5/8" PLASTERBOARD

MEMBER	CENTRES (Inch)	L (mm)
<b>129 FURRING CHANNEL</b>	24"	350
	18"	380
<b>308 FURRING CHANNEL</b>	24"	250
	18"	270
<b>125 TOP CROSS RAIL</b>	48"	250
	36"	260
<b>127 TOP CROSS RAIL</b>	48"	260
	36"	280
<b>128 TOP CROSS RAIL</b>	48"	370
	36"	420

- NOTE:
1. Maximum upstand to cantilever not to exceed 6".
  2. Maximum weight of light fitting not to exceed 5kg/m.
  3. Deflection limited to L/600
  4. Ceiling to be constructed in accordance with the JUDAH KEY-LOCK® installation guide
  5. Minimum backspan as shown – reducing the suspension hangers to 900 ctrs does not increase the cantilever.

# METAL CEILING BATTENS

Domestic for Internal Applications

Metal ceiling batten systems cut back on the cost of call-back maintenance when board is fixed directly to roof trusses.

Judah have a range of metal ceiling batten systems which are suitable for truss spacings from 600mm to 1200mm and for use in cyclonic and high wind areas. Refer to maximum span and spacing tables for the various ceiling Battens (see page [33-35](#)).

## 314 DIRECT FIXING CLIP

To accommodate the increasing use of timber "I" beams, the 314 Direct Fixing Clip has been designed with two extra nail or screw slots placed lower down on the clip, with an additional temporary holding tab to assist installation.

The temporary holding tab is tapped into the timber beam when the clip is at the required level, therefore freeing up both hands to permanently secure the clip with nails or screws through the two adjacent fixing slots.

## 390 BATTEN SWIVEL CLIP

With the ability to rotate 360°, the 390 Batten Swivel Clip can easily turn the ceiling batten on an angle that suits the change in roof truss direction.

It also incorporates the temporary holding tab for quick and easy installation

21

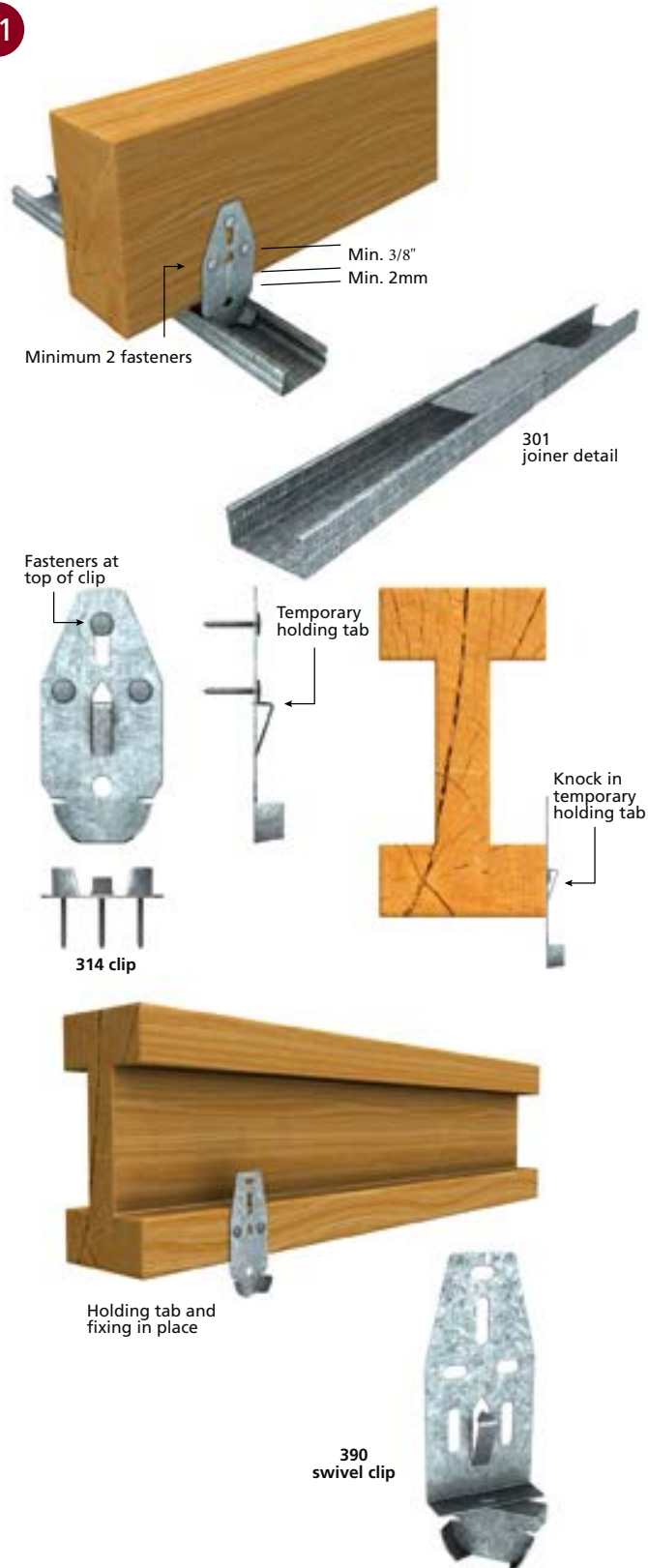

■ METAL CEILING BATTEN DETAILS



# METAL CEILING BATTENS (continued)

Domestic for Internal Applications (continued)

## CEILING BATTENS AND DIAPHRAGM ACTION

Ceiling battens that are clipped or suspended are not designed or tested to provide the necessary ceiling diaphragm action required by the code to enable wind forces to be transferred to bracing walls (refer AS 1684 7.3.3-1 Parts 2-3).

Tests have been conducted on Judah ceiling batten part number 303 by James Cook University to provide a satisfactory diaphragm system when direct fixed.

Contact Judah state offices for further information.

## IMPORTANT NOTE

Green timber should not come into contact with galvanised steel due to certain acidic substances in the timber which have a corrosive effect on the metallic coating. Some preservative treatments for wood can also have an adverse effect on metallic coated steel with which it is in contact. Timber treated with acidic preservatives of copper chromium arsenic (CCA) can be severely corrosive to the majority of metallic building components. Other timber treatments using Tanalith 'E' (Tanalised Ecowood) may cause pitting of the metal coating.

If any of the above timber is likely to come into contact with metallic coatings, the steel should be painted for protection.

The use of kiln-dried or appropriate dried timber is therefore recommended when metallic coated products are likely to be in contact.

22



TRAFFICABLE FLOOR INSTALLATION DETAIL



STANDARD TIMBER TRUSS INSTALLATION DETAIL

See Table 4 for nail or screw fixing information

## ■ CEILING BATTENS

**TABLE 4: FASTENER RECOMMENDATIONS**

BATTEN PART NO	NAIL LENGTH & DIAMETER					
	HARDWOOD			SOFTWOOD		
	LENGTH (mm)	DIA (mm)	TYPE	LENGTH (mm)	DIA (mm)	TYPE
<b>301</b>	40	2.8	Annular Ring Shank	50	2.8	Annular Ring Shank
<b>303</b>	30	2.8	Annular Ring Shank	40	2.8	Annular Ring Shank
<b>310</b>	30	2.8	Annular Ring Shank	40	2.8	Annular Ring Shank

BATTEN PART NO	SCREW LENGTH & SIZE		
	STEEL	HARDWOOD	SOFTWOOD
<b>301</b>	Wafer Head 10 x 24 x 16 Drill Point	Wafer Head 10 x 35 Type 17	Wafer Head 10 x 45 Type 17
<b>303/310</b>	Wafer Head 10 x 24 x 16 Drill Point	Pan Head 8 x 25 Type 17 10 x 25 Wafer	Wafer Head 10 x 45 Type 17

*NOTE: Minimum three threads penetration into substrate.*

**BUTT JOINT STITCHING BATTEN**

B005 Butt Joint Stitching Batten developed with the plasterboard industry provides a constant recess shape for finishing when installed as per the plasterboard manufacturer’s recommendations.

A faster, more cost-effective joint with greater strength is therefore achieved.

23

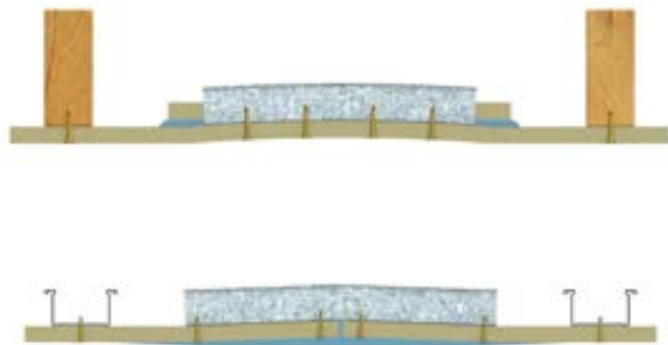

■ STITCHING BATTENS

# JUDAH 119 U CLIP™

The Judah U Clip™ adds a new dimension to the role of Top Cross Rails (TCR) in our KEY-LOCK® Ceiling



24

System as it allows the carrying capacity of the 127 and 128 TCR profiles to provide support for a variety of applications, when used in conjunction with threaded M6 suspension rod.

The U Clip™ is simply snapped into the underside of the TCR and then the threaded rod is screwed into the clip, using either 122 (threaded one end) or 123 (threaded both ends) Suspension Rods. The standard 121 Rod can be accommodated by joining it to the threaded rods with the 254 Joiner (also known as the 'Banana Clip').

The design tables (*Table 5*) enables a range of applications, including but not limited to :

- Suspension of signage
- Suspension of additional KEY-LOCK® framing to allow lining board to form feature soffites at varying levels beneath either blacked out voids or an existing ceiling.
- Lighting, both single light boxes and continuous lighting.
- Services not requiring stabilising.
- Fixing Furring Channel at varying angles beneath the TCR (when coupled with the 239 clip)
- Support for bridging beneath ducting, beams, etc. (see *Figure 24*)
- Suspending another ceiling beneath an existing KEY-LOCK® ceiling such as the Duo exposed grid system.



■ SUPPORT FOR BRIDGING BENEATH DUCTING

**TABLE 5: U CLIP DESIGN TABLES**

**SINGLE SPAN WITH SINGLE POINT LOAD**

SPAN	ALLOWABLE POINT LOAD (kg)			
	127 TCR spacing		128 TCR spacing	
	36"	48"	36"	48"
900	16	16	47	47
1200	8	7	25	24
1500	3	-	14	13
1800	-	-	8	7

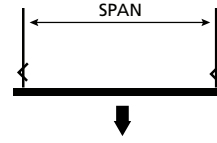

Allowable Load 'P'

**SINGLE SPAN WITH TWO EQUALLY SPACED POINT LOADS**

SPAN	ALLOWABLE POINT LOAD – EACH (kg)			
	127 TCR spacing		128 TCR spacing	
	36"	48"	36"	48"
900	10	9	28	27
1200	4	4	14	13
1500	2	-	7	7
1800	-	-	4	4

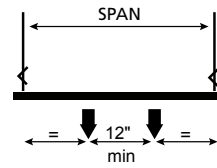

Allowable Individual Point Load 'P'

**DOUBLE SPAN WITH EQUAL POINT LOADS IN BOTH SPANS**

SPAN	ALLOWABLE POINT LOAD (kg)			
	127 TCR spacing		128 TCR spacing	
	36"	48"	36"	48"
900	32	32	50	50
1200	21	21	38	37
1500	12	11	24	23
1800	-	-	14	13

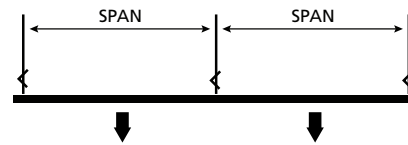

Allowable Load 'P'

**DOUBLE SPAN WITH TWO EQUALLY SPACED POINT LOADS IN BOTH SPANS**

SPAN	ALLOWABLE POINT LOAD (kg)			
	127 TCR spacing		128 TCR spacing	
	36"	48"	36"	48"
900	18	18	29	29
1200	12	11	20	19
1500	6	6	13	12
1800	-	-	7	7

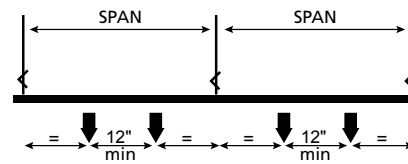

Allowable Individual Point Load 'P'

**NOTES:**

1. Allowable point load is specified in kg. Point loading considered as dead load only.
2. Deflection limited to  $L / 360$  under service load, for other limits adjust load accordingly.
3. The above tables assume construction in accordance with the Judah Keylock Manual.
4. The above tables are only valid for the JUDAH 119 U Clip installation.

# EXPRESS JOINT: CEILINGS

## Judah 155 Express Joint Furring Channel for Internal Applications

The 155 Express Joint Furring Channel is a 2" face width profile with a 10mm wide central strip which can be used together with complimentary clips from the KEY-LOCK® System for internal ceilings or wall finishes (see Figure 25). The profile's width allows the use of building boards requiring up to a 12mm edge distance for screwing whilst offering a 10mm wide express joint which is easily followed when sheeting the framing (see Figure 27).

The complimentary clips allow the 155 Express Joint Furring Channel to be direct fixed to timber joists or steel purlins and clipped into standard Top Cross Rail for a fully suspended ceiling (see Figure 28). This product is specified for use with particular specialised building boards by the manufacturers.

This is a special, made-to-order product and therefore it is important to check availability with an Authorised Judah Distributor, or Judah Sales Office.

Judah 155 Express Joint can also be used in wall finishes by directly fixing to wall substrates (see Figures 26,27 & 28).

### IMPORTANT NOTE:

The Judah Express Joint Furring Channel is for internal use only. Judah does not recommend it for exterior use.

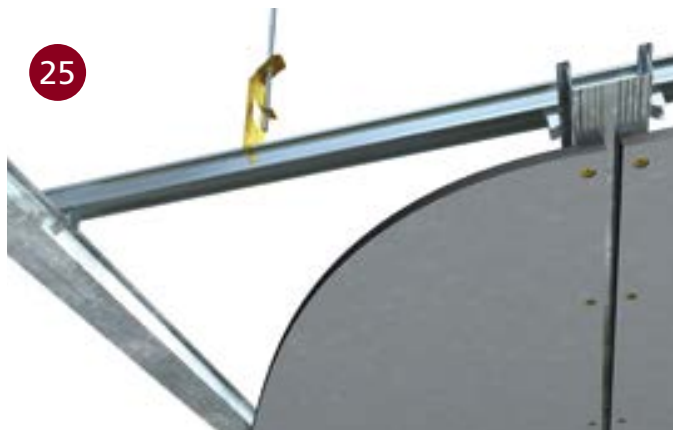

25

■ 155 USED IN INTERNAL CEILING

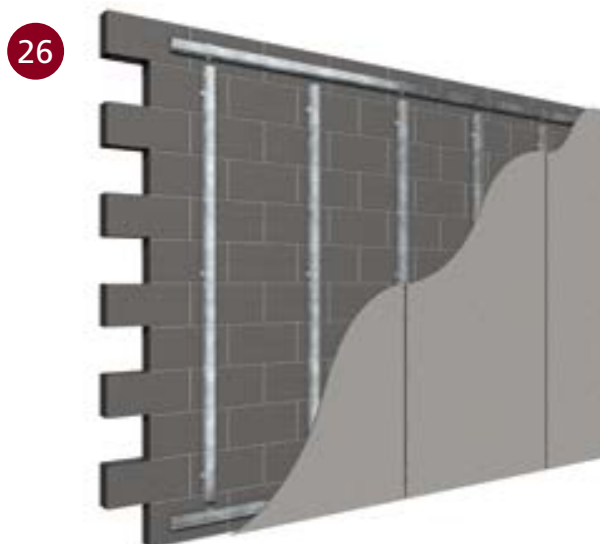

26

■ 155 USED IN INTERNAL WALL



27

■ 155 DETAIL

28



155 Furring Channel clipped to TCR



155 Furring Channel Fixed to Timber Joist

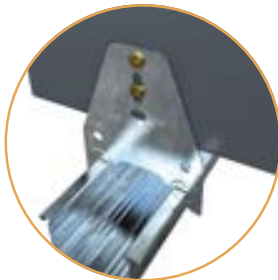

155 Furring Channel Fixed to Steel Purlins



155 Furring Channel Fixed to Wall

■ 155: TYPICAL APPLICATIONS

TABLE 6: 155 FURRING CHANNEL DIRECT FIX

N2 (W33) WIND LOADING

CLADDING DETAILS (Plasterboard)	FURRING CHANNEL SPACING			
	SINGLE SPAN		CONTINUOUS SPAN	
	450	600	450	600
1 x 3/8"	1740	1600	2160	1960
1 x 1/2"	1620	1480	2000	1840
1 x 5/8"	1460	1330	1810	1650
2 x 1/2"	1310	1190	1620	1480
2 x 5/8"	1170	1070	1450	1320

N3 (W41) WIND LOADING

CLADDING DETAILS (Plasterboard)	FURRING CHANNEL SPACING			
	SINGLE SPAN		CONTINUOUS SPAN	
	450	600	450	600
1 x 3/8"	1690	1530	1890	1590
1 x 1/2"	1620	1480	1830	1540
1 x 5/8"	1460	1330	1770	1480
2 x 1/2"	1310	1190	1620	1360
2 x 5/8"	1170	1070	1450	1280

NOTES:

1. Wind loading to AS4055 as follows: N2:  $V_{hu} = 40\text{m/s}$   $V_{hs} = 26\text{m/s}$   $C_{pe} = -0.3$   
N3:  $V_{hu} = 50\text{m/s}$   $V_{hs} = 32\text{m/s}$   $C_{pe} = -0.3$
2. Ultimate limit state: LC1: 1.2G + Wu
3. Serviceability limit state: LC2: G - Limit L/600  
LC3: G + Ws - Limit L/200 to AS 1170.0
4. N2 wind loading was previously W33, and N3 wind loading was previously W41.
5. The above tables are for internal ceilings in non-cyclonic regions.

TABLE 7: CEILING INSTALLATION WITH KEY-LOCK TCR

MAXIMUM CEILING LOAD: TCR SPAN 1200mm

SPACING OF 127 STANDARD TCR	FURRING CHANNEL SPACING	
	18"	24"
	ALLOWABLE CEILING WEIGHT (kg/m <sup>2</sup> )	
	155 FURRING CHANNEL	
3"	27	27
4'	19	19
5'	15	15
6'	9.1	5.9

SPACING OF 128 HEAVY DUTY TCR	FURRING CHANNEL SPACING	
	18"	24"
	ALLOWABLE CEILING WEIGHT (kg/m <sup>2</sup> )	
	155 FURRING CHANNEL	
3"	50	50
4'	37	37
5'	21	15
6'	9.1	5.9

NOTES:

1. The above tables give the allowable dead load for the various ceiling configurations. The calculated ceiling weight therefore does not have to be factored in accordance with ASINZS 2785.
2. Connections to be independently checked.
3. Deflection limited to L/360.
4. Lining contribution has been ignored in analysis.
5. Refer to details on Page 15 for external suspended ceiling systems.
6. Ultimate limit state: 1.4G + 1.7U. Serviceability limit state: G + U.

# IMPORTANT FIXING INFORMATION

## Suspending Ceilings from Purlins

Judah does not produce a suspension clip for attachment to the lip of steel purlins ('C' or 'Z' purlins, etc.) for the following reasons:

**AS/NZS 2785:2000 Suspended Ceilings – Design and Installation details the following in respect to this issue:**

- Section 4 Installation – Part 4.4: “In the case of purlins, the top fixing shall be made to the web of the purlin unless specifically designed otherwise”
- APPENDIX G Fixing (Informative): G2 Top Fixing, G2.1 Purlin Fixings:  
“Purlin fixings should be as follows:
  - A) Connections should be made to the web of the purlin, unless specifically designed otherwise
  - B) Where flange connections are necessary, they should be made as close as possible to the web of the purlin
  - C) Purlin manufacturers do not recommend attaching the top fixing to the lip of the purlin
  - D) Fixings should be selected and installed in accordance with the manufacturers specifications.”

# PRODUCT DATA SPECIFICATIONS

## Furring Channels/Battens

### MATERIAL SPECIFICATIONS

The sections are cold roll formed from steel strip manufactured to AS1397.

#### PART NO'S: 129/308/333/310

Steel Grade: G2

Yield Strength:  $F_y = 270$  MPa (typical)

Coating Grade: Z275 – 275g/m<sup>2</sup> zinc

#### PART NO'S: 301/303

Steel Grade: G550

Yield Strength:  $F_y = 550$  MPa

Coating Grade: zincalume AZ150 – 150g/m<sup>2</sup> alum/zinc

Base Metal Thickness: As specified

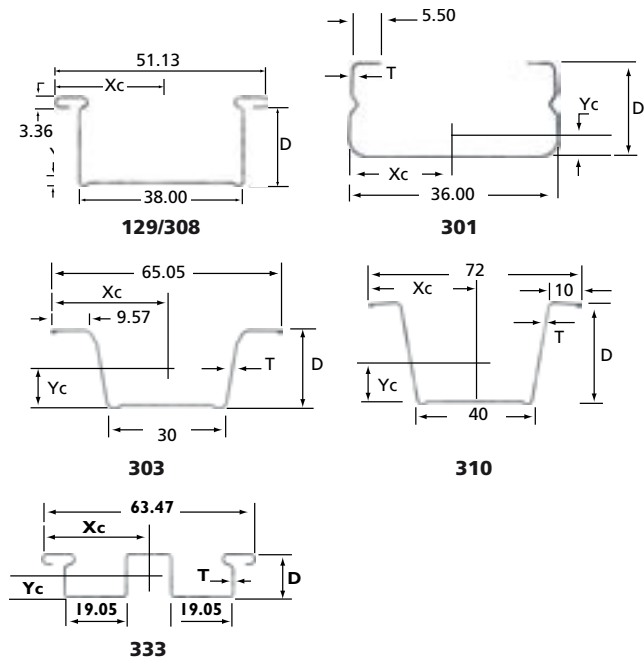

TABLE 8: FURRING CHANNELS & BATTENS – SECTION DIMENSIONS

BATTEN PART NO	AREA (mm <sup>2</sup> )	D (mm)	T (BMT) (mm)	X <sub>c</sub> (mm)	Y <sub>c</sub> (mm)	YIELD STRESS (MPa)	SELF-WEIGHT (kg/m)
129	59.6	27.3	0.50	25.56	13.04	270	0.468
308	48.2	16.0	0.50	25.56	7.70	270	0.378
333	63.2	12.7	0.50	31.74	6.44	270	0.496
301	33.2	16.3	0.42	18.00	5.81	550	0.261
303	45.1	23.5	0.42	32.52	11.48	550	0.354
310	66.0	35.0	0.55	36.00	15.97	270	0.518



# PRODUCT DATA SPECIFICATIONS (continued)

## Top Cross Rails

### MATERIAL SPECIFICATIONS

The sections are cold roll formed from zinc coated steel strip, which is manufactured to AS1397.

**Steel Grade:** G2

**Yield Strength:**  $F_y = 270$  MPa (typical)

**Coating Grade:** Z275 – 275g/m<sup>2</sup> zinc

**Base Metal Thickness:** As specified

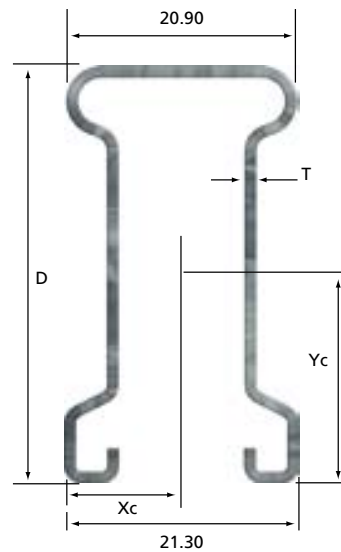

**125/127/128**

**TABLE 9: TOP CROSS RAILS – SECTION DIMENSIONS**

<b>BATTEN PART NO</b>	<b>AREA (mm<sup>2</sup>)</b>	<b>D (mm)</b>	<b>T (BMT) (mm)</b>	<b>Xc (mm)</b>	<b>Yc (mm)</b>	<b>YIELD STRESS (MPa)</b>	<b>SELF-WEIGHT (kg/m)</b>
<b>125</b>	48.2	26.35	0.55	10.65	14.18	270	0.378
<b>127</b>	65.7	26.35	0.75	10.65	14.20	270	0.516
<b>128</b>	84.2	38.65	0.75	10.65	20.41	270	0.661

# SPAN TABLES

## 129 Furring Channel: Direct Fix

### MAXIMUM SPANS: WIND LOADS N2 (0.29kPa ULT)

CLADDING DETAILS (Plasterboard)	FURRING CHANNEL SPACING			
	SINGLE SPAN		CONTINUOUS SPAN	
	12"	24"	12"	24"
1 x 3/8"	1245	1148	1713	1580
1 x 1/2"	1213	1119	1670	1540
1 x 5/8"	1184	1092	1630	1503
2 x 1/2"	1128	1041	1552	1432
2 x 5/8"	1088	1004	1498	1381



### MAXIMUM SPANS: WIND LOADS N3 (0.45 kPa ULT)

CLADDING DETAILS (Plasterboard)	FURRING CHANNEL SPACING			
	SINGLE SPAN		CONTINUOUS SPAN	
	12"	24"	12"	24"
1 x 3/8"	1125	1037	1547	1428
1 x 1/2"	1105	1018	1519	1401
1 x 5/8"	1085	1001	1494	1378
2 x 1/2"	1047	965	1440	1328
2 x 5/8"	1018	938	1400	1292

- NOTES: 1. Wind loading to AS4055 as follows: N2:  $V_{hu} = 40\text{m/s}$   $V_{hs} = 26\text{m/s}$   $C_{pi} = -0.3$  N3:  $V_{hu} = 50\text{m/s}$   $V_{hs} = 32\text{m/s}$   $C_{pi} = -0.3$   
 2. Ultimate limit state: LC1: 1.2G + Wu  
 3. Serviceability limit state: LC2: G - Limit L/600 LC3: G + Ws - Limit L/200 to AS 1170.0  
 4. N2 wind loading was previously W33, and N3 wind loading was previously W41.  
 5. The above tables are for internal ceilings in non-cyclonic regions.

### MAXIMUM SPANS: WIND LOADS 0.50 kPa – 1.00 kPa

CLADDING DETAILS (Plasterboard)	FURRING CHANNEL SPACING							
	0.50 kPa				0.60 kPa			
	SINGLE SPAN		CONTINUOUS SPAN		SINGLE SPAN		CONTINUOUS SPAN	
	12"	24"	12"	24"	12"	24"	12"	24"
1 x 3/8"	1097	1011	1510	1392	1049	967	1443	1331
1 x 1/2"	1078	995	1484	1369	1034	954	1423	1312
1 x 5/8"	1062	979	1461	1347	1020	941	1403	1295
2 x 1/2"	1026	946	1412	1302	990	913	1362	1256
2 x 5/8"	999	922	1375	1269	967	892	1331	1228

CLADDING DETAILS (Plasterboard)	FURRING CHANNEL SPACING							
	0.70 kPa				0.80 kPa			
	SINGLE SPAN		CONTINUOUS SPAN		SINGLE SPAN		CONTINUOUS SPAN	
	12"	24"	12"	24"	12"	24"	12"	24"
1 x 3/8"	1009	931	1389	1281	976	900	1343	1239
1 x 1/2"	997	919	1372	1265	965	890	1328	1225
1 x 5/8"	985	908	1355	1250	955	880	1314	1212
2 x 1/2"	959	885	1320	1217	932	860	1283	1183
2 x 5/8"	940	866	1293	1192	915	844	1259	1161

CLADDING DETAILS (Plasterboard)	FURRING CHANNEL SPACING							
	0.90 kPa				1.00 kPa			
	SINGLE SPAN		CONTINUOUS SPAN		SINGLE SPAN		CONTINUOUS SPAN	
	12"	24"	12"	24"	12"	24"	12"	24"
1 x 3/8"	947	873	1302	1202	922	850	1268	1170
1 x 1/2"	937	865	1290	1190	913	842	1257	1159
1 x 5/8"	928	856	1278	1178	905	835	1246	1149
2 x 1/2"	908	838	1250	1153	887	818	1221	1126
2 x 5/8"	893	824	1229	1133	873	806	1202	1108

- NOTES: 1. Stated pressure is the ultimate design wind load, including all local factors.  
 2. Deflection limited to the lesser of L/600 under dead load, or L/200 under dead plus service wind load.  
 3. Service wind load checked at 0.65 times the ultimate pressure.  
 4. Strength check of unrestrained flange in compression.  
 5. Connections to be independently checked.

# SPAN TABLES (continued)

## 308 Furring Channel: Direct Fix

### MAXIMUM SPANS: WIND LOADS N2 (0.29kPa ULT)

CLADDING DETAILS (Plasterboard)	FURRING CHANNEL SPACING			
	SINGLE SPAN		CONTINUOUS SPAN	
	12"	24"	12"	24"
1 x 3/8"	1018	933	1384	1269
1 x 1/2"	990	907	1359	1245
1 x 5/8"	965	885	1324	1215
2 x 1/2"	915	840	1170	1095
2 x 5/8"	881	808	1094	1027



### MAXIMUM SPANS: WIND LOADS N3 (0.45 kPa Ult)

CLADDING DETAILS (Plasterboard)	FURRING CHANNEL SPACING			
	SINGLE SPAN		CONTINUOUS SPAN	
	12"	24"	12"	24"
1 x 3/8"	913	837	1253	1149
1 x 1/2"	895	821	1228	1126
1 x 5/8"	878	806	1206	1106
2 x 1/2"	845	775	1160	1064
2 x 5/8"	820	752	1094	1027

- NOTES: 1. Wind loading to AS4055 as follows: N2:  $V_{hu} = 40\text{m/s}$   $V_{hs} = 26\text{m/s}$   $C_{pi} = -0.3$  N3:  $V_{hu} = 50\text{m/s}$   $V_{hs} = 32\text{m/s}$   $C_{pi} = -0.3$   
 2. Ultimate limit state: LC1:  $1.2G + Wu$   
 3. Serviceability limit state: LC2:  $G - \text{Limit } L/600$  LC3:  $G + Ws - \text{Limit } L/200$  to AS 1170.0  
 4. N2 wind loading was previously W33, and N3 wind loading was previously W41.  
 5. The above tables are for internal ceilings in non-cyclonic regions.

### MAXIMUM SPANS: WIND LOADS 0.20 kPa – 0.50 kPa

CLADDING DETAILS (Plasterboard)	FURRING CHANNEL SPACING							
	0.20 kPa				0.30 kPa			
	SINGLE SPAN		CONTINUOUS SPAN		SINGLE SPAN		CONTINUOUS SPAN	
	12"	24"	12"	24"	12"	24"	12"	24"
1 x 3/8"	1104	1012	1444	1317	1008	925	1320	1202
1 x 1/2"	1065	976	1460	1340	981	900	1347	1235
1 x 5/8"	1031	946	1415	1298	958	877	1313	1205
2 x 1/2"	968	888	1328	1218	909	835	1249	1145
2 x 5/8"	925	848	1268	1163	876	803	1202	1102

CLADDING DETAILS (Plasterboard)	FURRING CHANNEL SPACING							
	0.40 kPa				0.50 kPa			
	SINGLE SPAN		CONTINUOUS SPAN		SINGLE SPAN		CONTINUOUS SPAN	
	12"	24"	12"	24"	12"	24"	12"	24"
1 x 3/8"	940	863	1229	1119	888	815	1160	1055
1 x 1/2"	920	844	1263	1158	872	800	1198	1098
1 x 5/8"	901	827	1238	1135	858	787	1177	1080
2 x 1/2"	864	792	1185	1088	827	758	1135	1042
2 x 5/8"	837	767	1149	1053	805	738	1105	1003

- NOTES: 1. Stated pressure is the ultimate design wind load, including all local factors.  
 2. Deflection limited to the lesser of  $L/600$  under dead load, or  $L/200$  under dead plus service wind load.  
 3. Service wind load checked at 0.65 times the ultimate pressure.  
 4. Strength check of unrestrained flange in compression.  
 5. Connections to be independently checked.

### 310 Batten: Direct Fix

**MAXIMUM SPANS: WIND LOADS N2 (0.29kPa ULT)**

CLADDING DETAILS (Plasterboard)	BATTEN SPACING			
	SINGLE SPAN		CONTINUOUS SPAN	
	450	600	450	600
1 x 10mm	1197	1101	1645	1513
1 x 13mm	1166	1072	1602	1473
1 x 16mm	1137	1046	1563	1438
2 x 13mm	1081	995	1486	1368
2 x 16mm	1042	959	1432	1318



**MAXIMUM SPANS: WIND LOADS N3 (0.45 kPa ULT)**

CLADDING DETAILS (Plasterboard)	BATTEN SPACING			
	SINGLE SPAN		CONTINUOUS SPAN	
	450	600	450	600
1 x 10mm	1078	992	1482	1363
1 x 13mm	1058	973	1454	1337
1 x 16mm	1039	956	1428	1314
2 x 13mm	1001	921	1375	1265
2 x 16mm	972	894	1337	1230

NOTES: 1. Wind loading to AS4055 as follows: N2:  $V_{hu} = 40\text{m/s}$   $V_{hs} = 26\text{m/s}$   $C_{pi} = -0.3$  N3:  $V_{hu} = 50\text{m/s}$   $V_{hs} = 32\text{m/s}$   $C_{pi} = -0.3$   
 2. Ultimate limit state: LC1:  $1.2G + Wu$   
 3. Serviceability limit state: LC2: G - Limit L/600 LC3: G + Ws - Limit L/200 to AS 1170.0  
 4. N2 wind loading was previously W33, and N3 wind loading was previously W41.  
 5. The above tables are for internal ceilings in non-cyclonic regions.

**MAXIMUM SPANS: WIND LOADS 0.50 kPa – 1.00 kPa**

CLADDING DETAILS (Plasterboard)	BATTEN SPACING							
	0.50 kPa				0.60 kPa			
	SINGLE SPAN		CONTINUOUS SPAN		SINGLE SPAN		CONTINUOUS SPAN	
	450	600	450	600	450	600	450	600
1 x 10mm	1050	966	1443	1328	1003	923	1379	1268
1 x 13mm	1032	949	1419	1305	988	909	1359	1249
1 x 16mm	1015	934	1396	1284	975	896	1339	1232
2 x 13mm	980	902	1347	1240	945	869	1299	1195
2 x 16mm	954	878	1312	1207	923	849	1268	1167

CLADDING DETAILS (Plasterboard)	BATTEN SPACING							
	0.70 kPa				0.80 kPa			
	SINGLE SPAN		CONTINUOUS SPAN		SINGLE SPAN		CONTINUOUS SPAN	
	450	600	450	600	450	600	450	600
1 x 10mm	964	887	1325	1219	931	857	1280	1178
1 x 13mm	952	875	1308	1204	921	847	1265	1164
1 x 16mm	940	865	1292	1189	911	837	1250	1151
2 x 13mm	915	841	1257	1156	888	817	1220	1123
2 x 16mm	895	824	1231	1132	871	802	1197	1102

CLADDING DETAILS (Plasterboard)	BATTEN SPACING							
	0.90 kPa				1.00 kPa			
	SINGLE SPAN		CONTINUOUS SPAN		SINGLE SPAN		CONTINUOUS SPAN	
	450	600	450	600	450	600	450	600
1 x 10mm	903	830	1240	1141	878	807	1206	1110
1 x 13mm	893	822	1228	1130	869	800	1195	1099
1 x 16mm	885	814	1215	1119	860	793	1184	1089
2 x 13mm	865	796	1189	1094	844	777	1160	1067
2 x 16mm	850	782	1168	1075	830	764	1141	1050

NOTES: 1. Stated pressure is the ultimate design wind load, including all local factors.  
 2. Deflection limited to the lesser of L/600 under dead load, or L/200 under dead plus service wind load.  
 3. Service wind load checked at 0.65 times the ultimate pressure.  
 4. Strength check of unrestrained flange in compression.  
 5. Connections to be independently checked.

# SPAN TABLES (continued)

## 301 Batten: Direct Fix

**MAXIMUM SPANS:** WIND LOADS N2 (0.29kPa ULT)

CLADDING DETAILS (Plasterboard)	BATTEN SPACING			
	SINGLE SPAN		CONTINUOUS SPAN	
	450	600	450	600
<b>1 x 10mm</b>	950	900	1200	1200
<b>1 x 13mm</b>	950	900	1200	1200

**MAXIMUM SPANS:** WIND LOADS N3 (0.45 kPa ULt)

CLADDING DETAILS (Plasterboard)	BATTEN SPACING			
	SINGLE SPAN		CONTINUOUS SPAN	
	450	600	450	600
<b>1 x 10mm</b>	900	800	1200	1120
<b>1 x 13mm</b>	900	800	1200	1100

**NOTES:**

1. Wind loading to AS4055 as follows:
  - N2:  $V_{hu} = 40\text{m/s}$   $V_{hs} = 26\text{m/s}$   $C_{pi} = -0.3$
  - N3:  $V_{hu} = 50\text{m/s}$   $V_{hs} = 32\text{m/s}$   $C_{pi} = -0.3$
  - LC 1:  $1.2G + Wu$
2. Ultimate limit state:
  - LC2:  $G - \text{Limit LI600}$
3. Serviceability limit state:
  - LC3:  $G + Ws - \text{Limit LI200 to AS 1170.0}$



### 303 Cyclonic Batten: Direct Fix

**MAXIMUM SPANS: WIND LOADS N2 (0.29kPa ULT)**

CLADDING DETAILS (Plasterboard)	BATTEN SPACING			
	SINGLE SPAN		CONTINUOUS SPAN	
	450	600	450	600
1 x 10mm	945	871	1300	1200
1 x 13mm	920	850	1267	1168
1 x 16mm	900	830	1237	1141
2 x 13mm	856	790	1179	1087
2 x 16mm	826	762	1137	1049

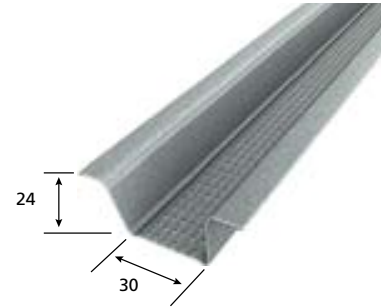

**MAXIMUM SPANS: WIND LOADS N3 (0.45 kPa ULT)**

CLADDING DETAILS (Plasterboard)	BATTEN SPACING			
	SINGLE SPAN		CONTINUOUS SPAN	
	450	600	450	600
1 x 10mm	854	787	1175	1084
1 x 13mm	838	773	1154	1064
1 x 16mm	824	760	1134	1046
2 x 13mm	795	733	1093	1009
2 x 16mm	773	713	1063	981

NOTES: 1. Wind loading to AS4055 as follows:  $N2: V_{hu} = 40\text{m/s}$   $V_{fs} = 26\text{m/s}$   $C_{pi} = -0.3$   
 $N3: V_{hu} = 50\text{m/s}$   $V_{fs} = 32\text{m/s}$   $C_{pi} = -0.3$   
 2. Ultimate limit state:  $LC1: 1.2G + W_u$   
 3. Serviceability limit state:  $LC2: G - \text{Limit } L/600$   $LC3: G + W_s - \text{Limit } L/200 \text{ to AS } 1170.0$

**MAXIMUM SPANS: WIND LOADS 0.50 kPa – 1.00 kPa**

CLADDING DETAILS (Plasterboard)	BATTEN SPACING							
	0.50 kPa				0.60 kPa			
	SINGLE SPAN		CONTINUOUS SPAN		SINGLE SPAN		CONTINUOUS SPAN	
	450	600	450	600	450	600	450	600
1 x 10mm	833	767	1145	1057	796	735	1095	1010
1 x 13mm	819	755	1128	1039	784	724	1081	996
1 x 16mm	805	743	1109	1022	774	714	1066	983
2 x 13mm	779	719	1073	989	752	694	1035	955
2 x 16mm	759	700	1045	963	735	678	1010	933

CLADDING DETAILS (Plasterboard)	BATTEN SPACING							
	0.70 kPa				0.80 kPa			
	SINGLE SPAN		CONTINUOUS SPAN		SINGLE SPAN		CONTINUOUS SPAN	
	450	600	450	600	450	600	450	600
1 x 10mm	766	707	1055	973	741	684	1020	941
1 x 13mm	756	699	1042	961	733	676	1009	931
1 x 16mm	747	690	1030	950	725	669	998	920
2 x 13mm	729	672	1003	925	708	653	975	899
2 x 16mm	714	658	982	906	695	641	956	883

CLADDING DETAILS (Plasterboard)	BATTEN SPACING							
	0.90 kPa				1.00 kPa			
	SINGLE SPAN		CONTINUOUS SPAN		SINGLE SPAN		CONTINUOUS SPAN	
	450	600	450	600	450	600	450	600
1 x 10mm	719	664	990	913	700	646	963	888
1 x 13mm	712	657	980	904	694	640	955	881
1 x 16mm	705	650	970	895	687	634	946	873
2 x 13mm	690	637	950	877	674	622	927	856
2 x 16mm	679	626	933	862	664	612	913	842

NOTES: 1. Stated pressure is the ultimate design wind load, including all local factors.  
 2. Deflection limited to the lesser of L/600 under dead load, or L/200 under dead plus service wind load.  
 3. Service wind load checked at 0.65 times the ultimate pressure.  
 4. Strength check of unrestrained flange in compression.  
 5. Connections to be independently checked.

# LOAD TABLES

## 125 Top Cross Rail x 0.55bmt

### MAXIMUM CEILING LOAD: TCR SPAN 900mm

SPACING OF TOP CROSS RAIL	FURRING CHANNEL SPACING			
	450		600	
	ALLOWABLE CEILING WEIGHT (kg/m <sup>2</sup> )			
	129	308	129	308
900	49	41	49	30
1200	36	15	36	11
1500	21	6.4	15	4.1
1800	9.1	–	5.9	–



### MAXIMUM CEILING LOAD: TCR SPAN 1200mm

SPACING OF TOP CROSS RAIL	FURRING CHANNEL SPACING			
	450		600	
	ALLOWABLE CEILING WEIGHT (kg/m <sup>2</sup> )			
	129	308	129	308
900	19	19	19	19
1200	13	13	13	11
1500	10	6.4	10	4.1
1800	7.9	–	5.9	–

### MAXIMUM CEILING LOAD: TCR SPAN 1500mm

SPACING OF TOP CROSS RAIL	FURRING CHANNEL SPACING			
	450		600	
	ALLOWABLE CEILING WEIGHT (kg/m <sup>2</sup> )			
	129	308	129	308
900	8.1	8.1	8.1	8.1
1200	5.2	5.2	5.2	5.2
1500	3.4	3.4	3.4	3.4
1800	–	–	–	–

#### NOTES:

1. The above tables give the allowable dead load for the various ceiling configurations. The calculated ceiling weight therefore does not have to be factored in accordance with AS/NZS 2785.
2. Connections to be independently checked.
3. Deflection limited to L/360.
4. Lining contribution has been ignored in analysis.
5. Refer to details on Page 15 for external suspended ceiling systems.
6. Ultimate limit state: 1.4G + 1.7U. Serviceability limit state: G + U.

## 127 Top Cross Rail x 0.75bmt

### MAXIMUM CEILING LOAD: TCR SPAN 900mm

SPACING OF TOP CROSS RAIL	FURRING CHANNEL SPACING			
	450		600	
	ALLOWABLE CEILING WEIGHT (kg/m <sup>2</sup> )			
	129	308	129	308
900	67	41	67	30
1200	50	15	37	11
1500	21	6.4	15	4.1
1800	9.1	-	5.9	-



### MAXIMUM CEILING LOAD: TCR SPAN 1200mm

SPACING OF TOP CROSS RAIL	FURRING CHANNEL SPACING			
	450		600	
	ALLOWABLE CEILING WEIGHT (kg/m <sup>2</sup> )			
	129	308	129	308
900	27	27	27	27
1200	19	15	19	11
1500	15	6.4	15	4.1
1800	9.1	-	5.9	-

### MAXIMUM CEILING LOAD: TCR SPAN 1500mm

SPACING OF TOP CROSS RAIL	FURRING CHANNEL SPACING			
	450		600	
	ALLOWABLE CEILING WEIGHT (kg/m <sup>2</sup> )			
	129	308	129	308
900	12	12	12	12
1200	8.4	8.4	8.4	8.4
1500	6.1	6.1	6.1	4.1
1800	4.6	-	4.6	-

#### NOTES:

1. The above tables give the allowable dead load for the various ceiling configurations. The calculated ceiling weight therefore does not have to be factored in accordance with AS/NZS 2785.
2. Connections to be independently checked.
3. Deflection limited to L/360.
4. Lining contribution has been ignored in analysis.
5. Refer to details on Page 15 for external suspended ceiling systems.
6. Ultimate limit state: 1.4G + 1.7U. Serviceability limit state: G + U.



# LOAD TABLES (continued)

## 128 Top Cross Rail x 0.75bmt

### MAXIMUM CEILING LOAD: TCR SPAN 1200mm

SPACING OF TOP CROSS RAIL	FURRING CHANNEL SPACING			
	450		600	
	ALLOWABLE CEILING WEIGHT (kg/m <sup>2</sup> )			
	129	308	129	308
900	50	41	50	30
1200	37	15	37	11
1500	21	6.4	15	4.1
1800	9.1	–	5.9	–

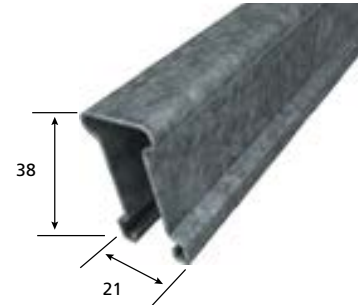

### MAXIMUM CEILING LOAD: TCR SPAN 1500mm

SPACING OF TOP CROSS RAIL	FURRING CHANNEL SPACING			
	450		600	
	ALLOWABLE CEILING WEIGHT (kg/m <sup>2</sup> )			
	129	308	129	308
900	22	22	22	22
1200	16	15	16	11
1500	12	6.4	15	4.1
1800	9.1	–	5.9	–

### MAXIMUM CEILING LOAD: TCR SPAN 1800mm

SPACING OF TOP CROSS RAIL	FURRING CHANNEL SPACING			
	450		600	
	ALLOWABLE CEILING WEIGHT (kg/m <sup>2</sup> )			
	129	308	129	308
900	10	10	10	10
1200	7	7	7	7
1500	5	5	5	5
1800	3	–	3	–

#### NOTES:

1. The above tables give the allowable dead load for the various ceiling configurations. The calculated ceiling weight therefore does not have to be factored in accordance with AS/NZS 2785.
2. Connections to be independently checked.
3. Deflection limited to L/360.
4. Lining contribution has been ignored in analysis.
5. Refer to details on Page 15 for external suspended ceiling systems.
6. Ultimate limit state: 1.4G + 1.7U. Serviceability limit state: G + U.